

AIRSPRING SEAT DETAIL

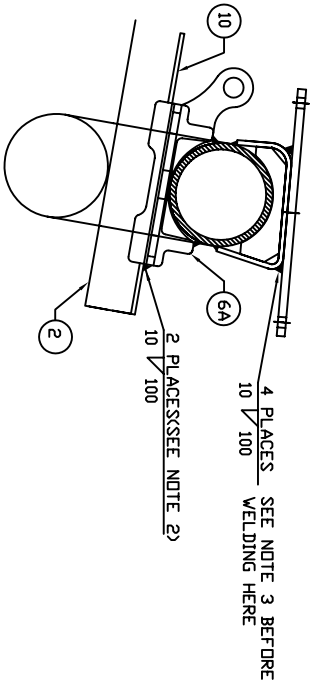

AXLE SADDLE AND AIRSPRING SEAT WELDING DETAIL

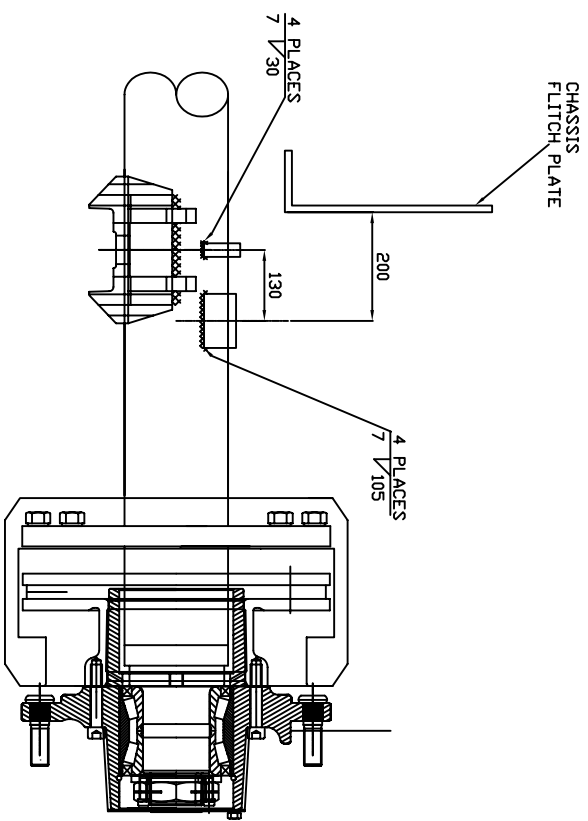

AIRSPRING SEAT POSITION AND WELDING DETAIL

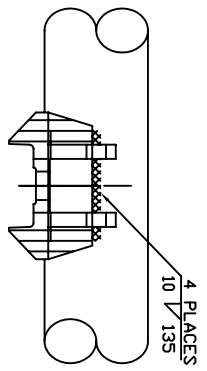

SADDLE WELDMENT

DO NOT SCALE-IF IN DOUBT ASK	DESIGNED FOR	DATE	CHECKED	TITLE
THIRD ANGLE PROJECTION	RETRO - NO ALE DIMENSIONS - 7500 kgs	27 SEP 05		INSTALLATION
ALL DIMENSIONS ARE IN MILLIMETRES	CONDIMENTS TO CARRY	ALL ALTERATIONS TO BE VIA CAD	SCALE	RM (U) 20
ORIGINAL FRAME SIZE 809mm x 562mm	NO DECIMALS	ESTIMATED ACTUAL	1:5	DRAWING NO. 18254
	NO SHARP EDGES TO BE REMOVED			SHEET 2 OF 2
	UNSPECIFIED TOLERANCES			A1
	± 0.2mm			
	± 0.25mm			
	± 0.3mm			
	± 0.4mm			
	± 0.5mm			
	± 0.6mm			
	± 0.7mm			
	± 0.8mm			
	± 0.9mm			
	± 1.0mm			
	± 1.2mm			
	± 1.5mm			
	± 2.0mm			
	± 2.5mm			
	± 3.0mm			
	± 4.0mm			
	± 5.0mm			
	± 6.0mm			
	± 8.0mm			
	± 10.0mm			
	± 12.0mm			
	± 15.0mm			
	± 20.0mm			
	± 25.0mm			
	± 30.0mm			
	± 40.0mm			
	± 50.0mm			
	± 60.0mm			
	± 70.0mm			
	± 80.0mm			
	± 100.0mm			
	± 120.0mm			
	± 150.0mm			
	± 200.0mm			
	± 250.0mm			
	± 300.0mm			
	± 400.0mm			
	± 500.0mm			
	± 600.0mm			
	± 700.0mm			
	± 800.0mm			
	± 1000.0mm			
	± 1200.0mm			
	± 1500.0mm			
	± 2000.0mm			
	± 2500.0mm			
	± 3000.0mm			
	± 4000.0mm			
	± 5000.0mm			
	± 6000.0mm			
	± 8000.0mm			
	± 10000.0mm			
	± 12000.0mm			
	± 15000.0mm			
	± 20000.0mm			
	± 25000.0mm			
	± 30000.0mm			
	± 40000.0mm			
	± 50000.0mm			
	± 60000.0mm			
	± 80000.0mm			
	± 100000.0mm			
	± 120000.0mm			
	± 150000.0mm			
	± 200000.0mm			
	± 250000.0mm			
	± 300000.0mm			
	± 400000.0mm			
	± 500000.0mm			
	± 600000.0mm			
	± 800000.0mm			
	± 1000000.0mm			
	± 1200000.0mm			
	± 1500000.0mm			
	± 2000000.0mm			
	± 2500000.0mm			
	± 3000000.0mm			
	± 4000000.0mm			
	± 5000000.0mm			
	± 6000000.0mm			
	± 8000000.0mm			
	± 10000000.0mm			
	± 12000000.0mm			
	± 15000000.0mm			
	± 20000000.0mm			
	± 25000000.0mm			
	± 30000000.0mm			
	± 40000000.0mm			
	± 50000000.0mm			
	± 60000000.0mm			
	± 80000000.0mm			
	± 100000000.0mm			
	± 120000000.0mm			
	± 150000000.0mm			
	± 200000000.0mm			
	± 250000000.0mm			
	± 300000000.0mm			
	± 400000000.0mm			
	± 500000000.0mm			
	± 600000000.0mm			
	± 800000000.0mm			
	± 1000000000.0mm			
	± 1200000000.0mm			
	± 1500000000.0mm			
	± 2000000000.0mm			
	± 2500000000.0mm			
	± 3000000000.0mm			
	± 4000000000.0mm			
	± 5000000000.0mm			
	± 6000000000.0mm			
	± 8000000000.0mm			
	± 10000000000.0mm			
	± 12000000000.0mm			
	± 15000000000.0mm			
	± 20000000000.0mm			
	± 25000000000.0mm			
	± 30000000000.0mm			
	± 40000000000.0mm			
	± 50000000000.0mm			
	± 60000000000.0mm			
	± 80000000000.0mm			
	± 100000000000.0mm			
	± 120000000000.0mm			
	± 150000000000.0mm			
	± 200000000000.0mm			
	± 250000000000.0mm			
	± 300000000000.0mm			
	± 400000000000.0mm			
	± 500000000000.0mm			
	± 600000000000.0mm			
	± 800000000000.0mm			
	± 1000000000000.0mm			
	± 1200000000000.0mm			
	± 1500000000000.0mm			
	± 2000000000000.0mm			
	± 2500000000000.0mm			
	± 3000000000000.0mm			
	± 4000000000000.0mm			
	± 5000000000000.0mm			
	± 6000000000000.0mm			
	± 8000000000000.0mm			
	± 10000000000000.0mm			
	± 12000000000000.0mm			
	± 15000000000000.0mm			
	± 20000000000000.0mm			
	± 25000000000000.0mm			
	± 30000000000000.0mm			
	± 40000000000000.0mm			
	± 50000000000000.0mm			
	± 60000000000000.0mm			
	± 80000000000000.0mm			
	± 100000000000000.0mm			
	± 120000000000000.0mm			
	± 150000000000000.0mm			
	± 200000000000000.0mm			
	± 250000000000000.0mm			
	± 300000000000000.0mm			
	± 400000000000000.0mm			
	± 500000000000000.0mm			
	± 600000000000000.0mm			
	± 800000000000000.0mm			
	± 1000000000000000.0mm			
	± 1200000000000000.0mm			
	± 1500000000000000.0mm			
	± 2000000000000000.0mm			
	± 2500000000000000.0mm			
	± 3000000000000000.0mm			
	± 4000000000000000.0mm			
	± 5000000000000000.0mm			
	± 6000000000000000.0mm			
	± 8000000000000000.0mm			
	± 10000000000000000.0mm			
	± 12000000000000000.0mm			
	± 15000000000000000.0mm			
	± 20000000000000000.0mm			
	± 25000000000000000.0mm			
	± 30000000000000000.0mm			
	± 40000000000000000.0mm			
	± 50000000000000000.0mm			
	± 60000000000000000.0mm			
	± 80000000000000000.0mm			
	± 100000000000000000.0mm			
	± 120000000000000000.0mm			
	± 150000000000000000.0mm			
	± 200000000000000000.0mm			
	± 250000000000000000.0mm			
	± 300000000000000000.0mm			
	± 400000000000000000.0mm			
	± 500000000000000000.0mm			
	± 600000000000000000.0mm			
	± 800000000000000000.0mm			
	± 1000000000000000000.0mm			
	± 1200000000000000000.0mm			
	± 1500000000000000000.0mm			
	± 2000000000000000000.0mm			
	± 2500000000000000000.0mm			
	± 3000000000000000000.0mm			
	± 4000000000000000000.0mm			
	± 5000000000000000000.0mm			
	± 6000000000000000000.0mm			
	± 8000000000000000000.0mm			
	± 10000000000000000000.0mm			
	± 12000000000000000000.0mm			
	± 15000000000000000000.0mm			
	± 20000000000000000000.0mm			
	± 25000000000000000000.0mm			
	± 30000000000000000000.0mm			
	± 40000000000000000000.0mm			
	± 50000000000000000000.0mm			
	± 60000000000000000000.0mm			
	± 80000000000000000000.0mm			
	± 100000000000000000000.0mm			
	± 120000000000000000000.0mm			
	± 150000000000000000000.0mm			
	± 200000000000000000000.0mm			
	± 250000000000000000000.0mm			
	± 300000000000000000000.0mm			
	± 400000000000000000000.0mm			
	± 500000000000000000000.0mm			
	± 600000000000000000000.0mm			
	± 800000000000000000000.0mm			
	± 1000000000000000000000.0mm			
	± 1200000000000000000000.0mm			
	± 1500000000000000000000.0mm			
	± 2000000000000000000000.0mm			
	± 2500000000000000000000.0mm			
	± 3000000000000000000000.0mm			
	± 4000000000000000000000.0mm			
	± 5000000000000000000000.0mm			
	± 6000000000000000000000.0mm			
	± 8000000000000000000000.0mm			
	± 10000000000000000000000.0mm			
	± 120000000000			

Suspension Pressure Characteristic

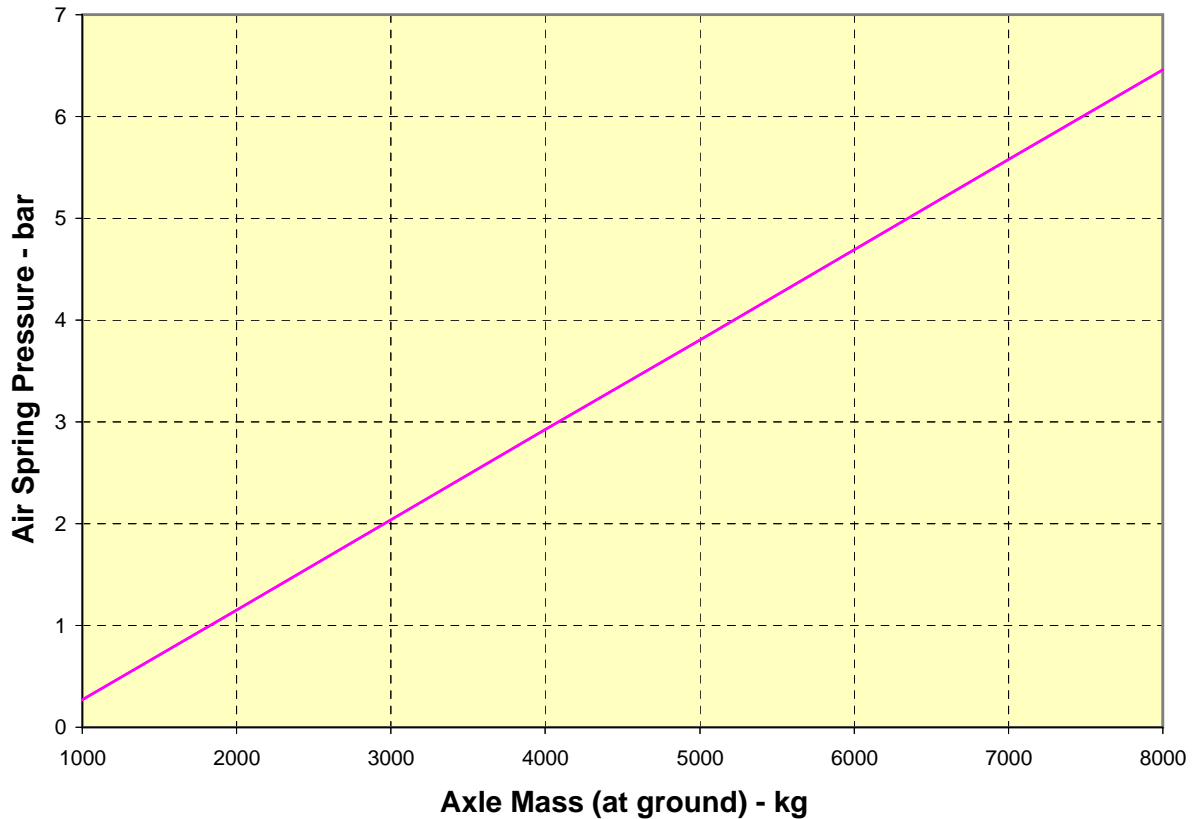

Load Pressure Characteristic - Granning Suspension Models

RME 19/20/25/30 - 75

This pressure to load characteristic refers to :

Suspension model **RME 19 - 75**
 RME 20 - 75
 RME 25 - 75
 RME 30 - 75

Installation drawing no. **18200**

Maximum Design Axle Load **7500kg**

The above characteristic is intended as a guide, manufacturing tolerances on the componentry may cause individual suspensions to vary. To obtain a high degree of accuracy requires that the suspension be calibrated over a flat and accurate scale.

This characteristic assumes an unsprung mass of 750kg.

SUSPENSION
CHARACTERISTIC

1000	0.268886	DIMENSION L₁ (mm)	528
2000	1.153379	DIMENSION L₂ (mm)	628
3000	2.037872		
4000	2.922365	SPRING RATE :	0.840764
5000	3.806858		
6000	4.691351		
7000	5.575844	AIRSPRING TYPE :	IT15M-6
8000	6.460338		
9000	7.344831	MAX LOAD (N)	31660
10000	8.229324	MIN LOAD (N)	13010
11000	9.113817	MAX PRESS (bar)	7
		MIN PRESS (bar)	3
			4662.5 (N/bar)
			0.000214 (bar/N)