



Granning Lynx UK
Additional Axle EBS
System

DRIVERS MANUAL

EBS Truck Conversion with Granning EBS additional axle package

Vehicle Manufacturer:

Model:

Chassis Number:

Vehicle Converter:

Additional EBS System Manufacturer:

Charging Valve Opening Pressure:.....Bar

Post conversion: Tractor Rigid drawbar Rigid Axle position: Mid Tag

Number of suspension Height sensors: one two

DRIVER INSTRUCTIONS

- **On vehicle ignition driver should check EBS warning light for additional axle. To show system connection and operation warning light will illuminate initially for 3 seconds and go out, if no faults are present. Or in some cases after service the light will remain on until vehicle has been moved above 7km/h. (if no light on ignition see troubleshooting section)**
- **In an emergency situation where one of the service brake circuits have failed, the driver should be aware that emergency braking will still be ‘Under foot’, as the two remaining axles should still function.
NOTE: With additional axle lifted there are no benefits in braking from this axle and in this case emergency braking would be as declared by the original vehicle manufacturer, refer to manufacturers specification.**
- **The driver should also be aware that as the parking brake is applied, the additional axle service brakes are applied with the handbrake in the ‘Test position’, once the handbrake is in the park position the additional axle service chambers are released and any spring brakes fitted are applied.**
- **Auto lower system operation: from a cab mounted switch the driver can operate the third axle lift/lower system. The system in its normal state will leave the additional axle on the ground unless instructed to lift by the driver. The axle will remain lifted until the driver lowers it again, or the system determines the drive axle is approaching its plated weight, when it will lower automatically.**
- **The auto lower system does have a traction control feature that will allow the driver to lift the additional axle for 90 seconds, Unless by UK legislation, the vehicle is moving over 30km/h or by lifting the addition axle load transferred imposes more than 130% of the drive axle plated weight**

GRANNING LYNX STAND ALONE EBS SYSTEM DIAGRAM
 (COVERING TRACTOR TO RIGID/DB, RIGID TO RIGID AND RIGID TO RIGID DB)
 (ALSO COVERS TRACTOR TO TRACTOR MID OR TAG AXLE CONVERSIONS)

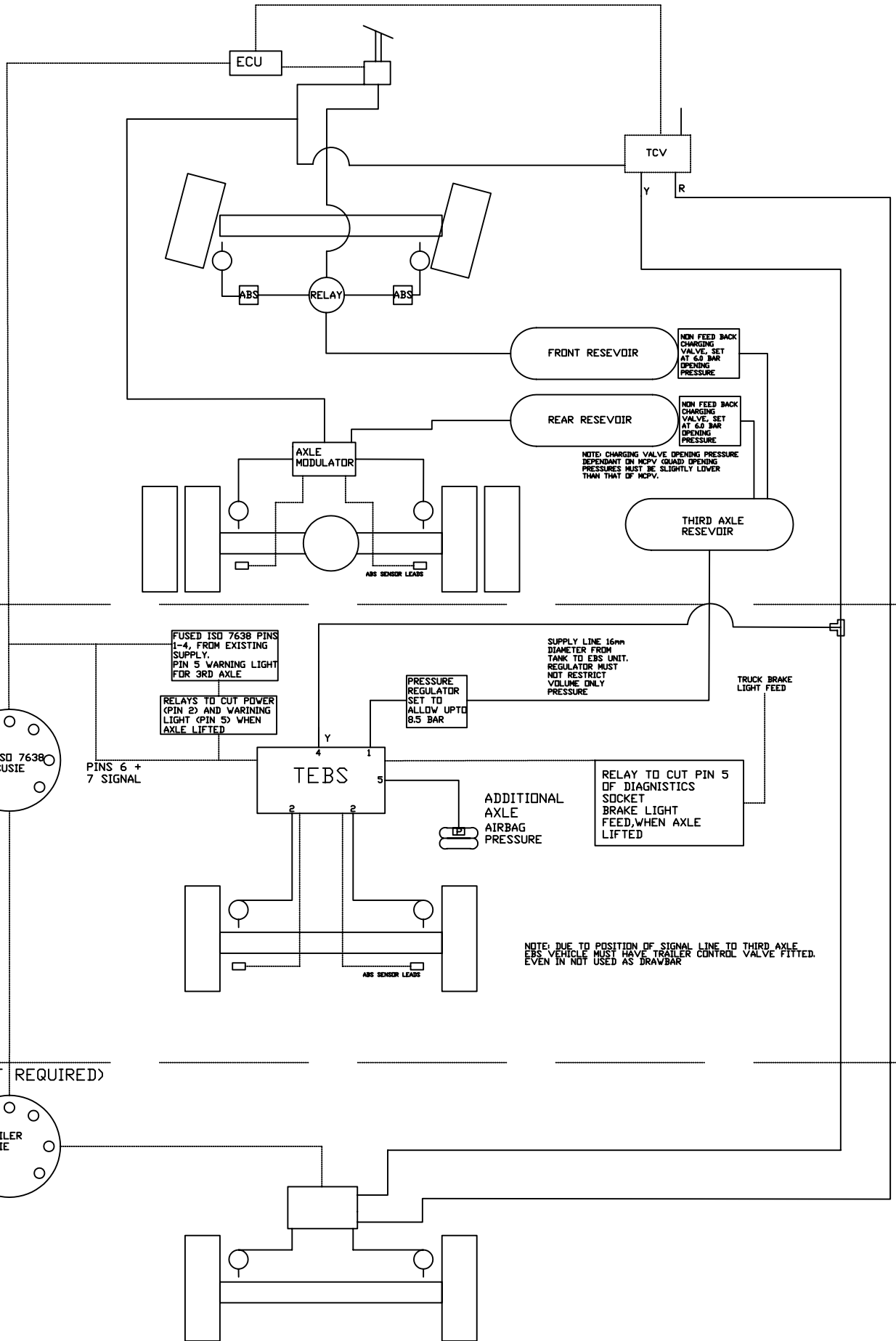

WABCO EBS UNIT CONNECTIONS

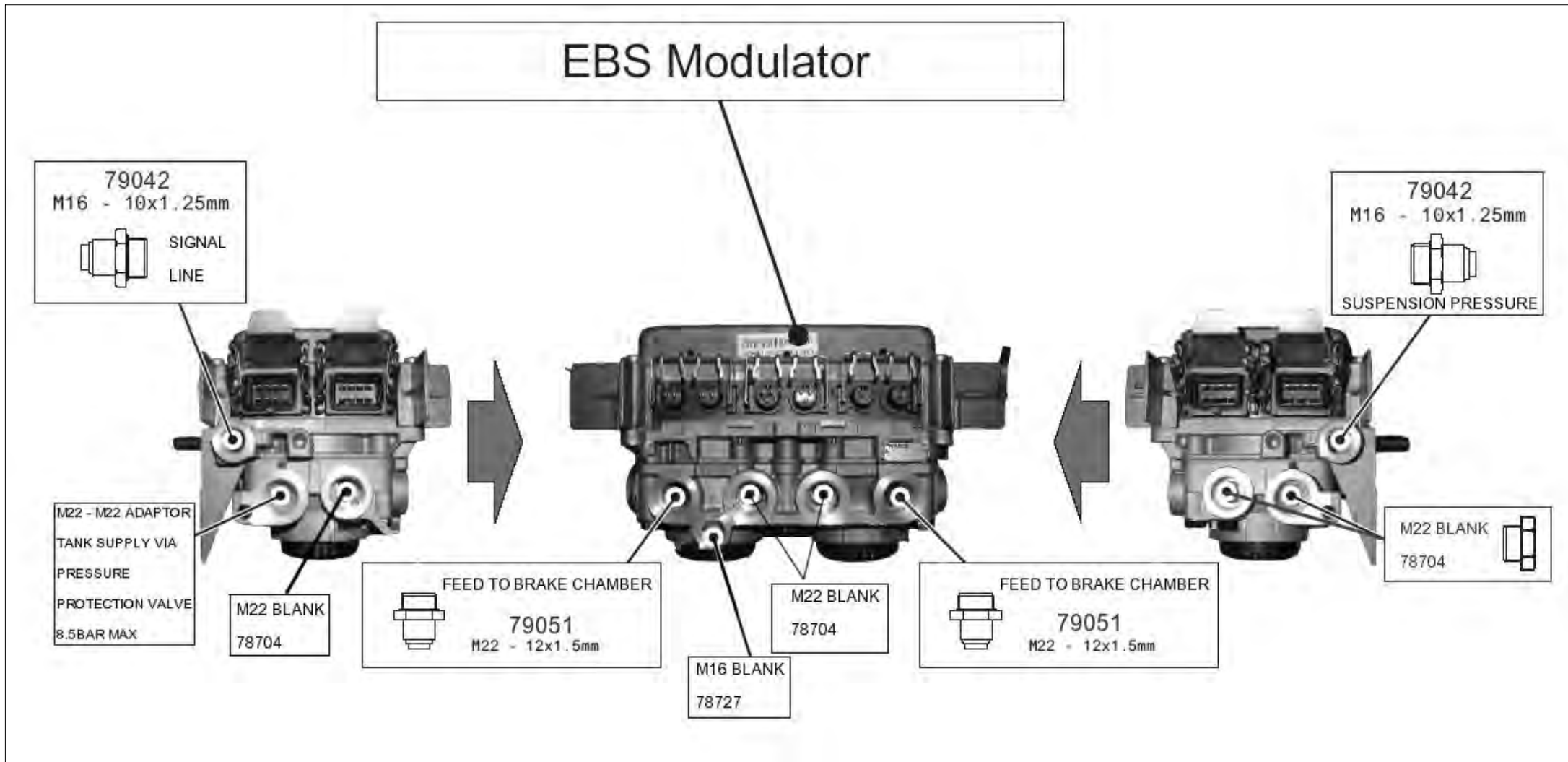

IN/OUT2

external demand sensor / telematics

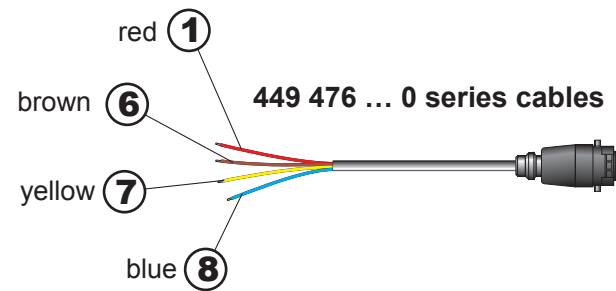

- ① Switched Output 3 / External Demand Sensor (KI15, 3A)
- ② Ground ECU
- ③ Input - External Demand sensor
- ⑤ KI30 (not fused)
- ⑥ Ground ECU
- ⑦ CAN 2 - Hi
- ⑧ CAN 2 - Lo

RSS Installation Requirements

Limits required to guarantee correct RSS function
- for modulator 480 102 014 0

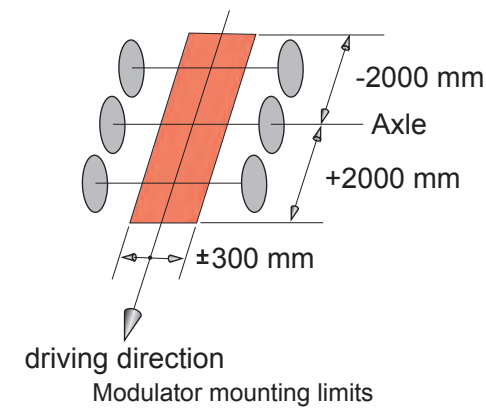
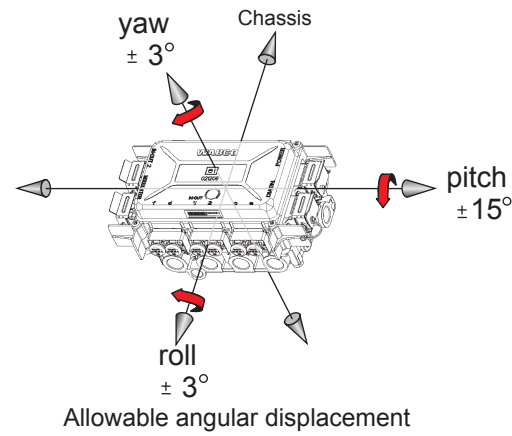

POWER - ISO 7638 / TCE

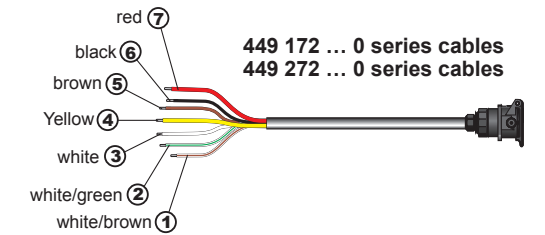

- ① ISO7638 CAN Lo (standard 24v, TCE 5v)
- ② ISO7638 CAN Hi (standard 24v, TCE 5v)
- ③ ISO7638 Warning Lamp (Not with TCE version)
- ④ ISO7638 Ground (Not with TCE version)
- ⑤ ISO7638 Solenoid Ground (KI 31) (GND with TCE version)
- ⑥ ISO7638 24v ECU (KI 15) (Not with TCE version)
- ⑦ ISO7638 24v KI 30 (Plus with TCE Version)

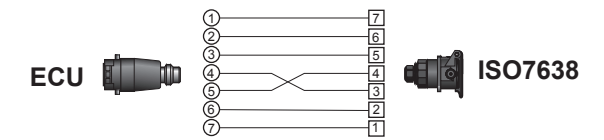

- ① Switched Output 3 (KI15, 3A)
- ② Ground ECU
- ③ Exhaust solenoid +24v
- ④ Redundancy Valve +24v
- ⑤ Input - Pressure Sensor EBS Relay Valve
- ⑥ Solenoid Valve - Ground
- ⑦ Inlet Solenoid +24v
- ⑧ Redundancy Valve - Ground

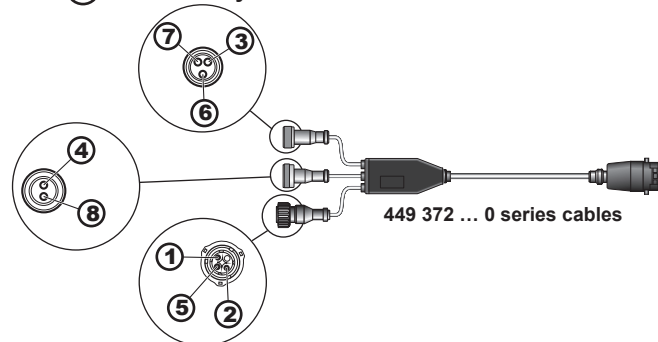

MODULATOR - 3rd modulator

WABCO Vehicle Control Systems
An American Standard Company

www.wabco-auto.com



wheel speed sensors f,d

wheel speed sensors c,e

- ① Switched Output 5 (24v)
- ② ECU Ground
- ③ Input Axle load Sensor / Traction Help

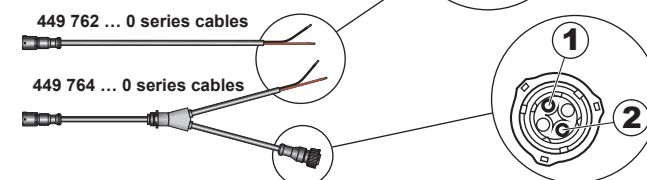

IN/OUT1 - traction help

- ① 5v
- ② ECU Ground
- ③ Input wear sensor

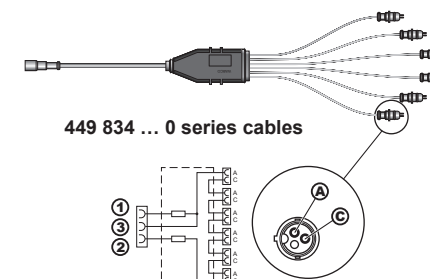

⊖ - wear indication

- ① ISO9141 K-Line
- ② Switched Output 4 (Diagnostic Supply)
- ③ ECU Ground
- ④ Switched Output 2 (ECAS/ELM/ILS2)
- ⑤ Stoplight ⊕
- ⑥ Battery Load Output (ECAS)
- ⑦ ECU Ground (Stoplight ⊖)
- ⑧ Switched Output 1 (ISS/ILS 1)

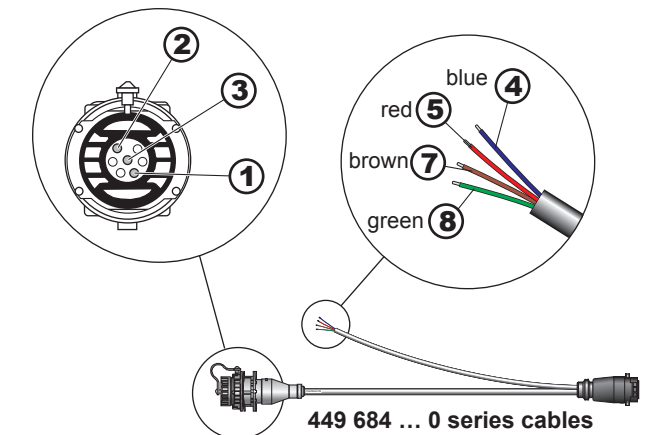

DIAGN.

diagnostics/stoplight/ISS/ILS/ECAS/ELM/battery

WABCO

D-Series Trailer EBS

SAFETY DRIVES US

KNORR-BREMSE EBS UNIT CONNECTIONS

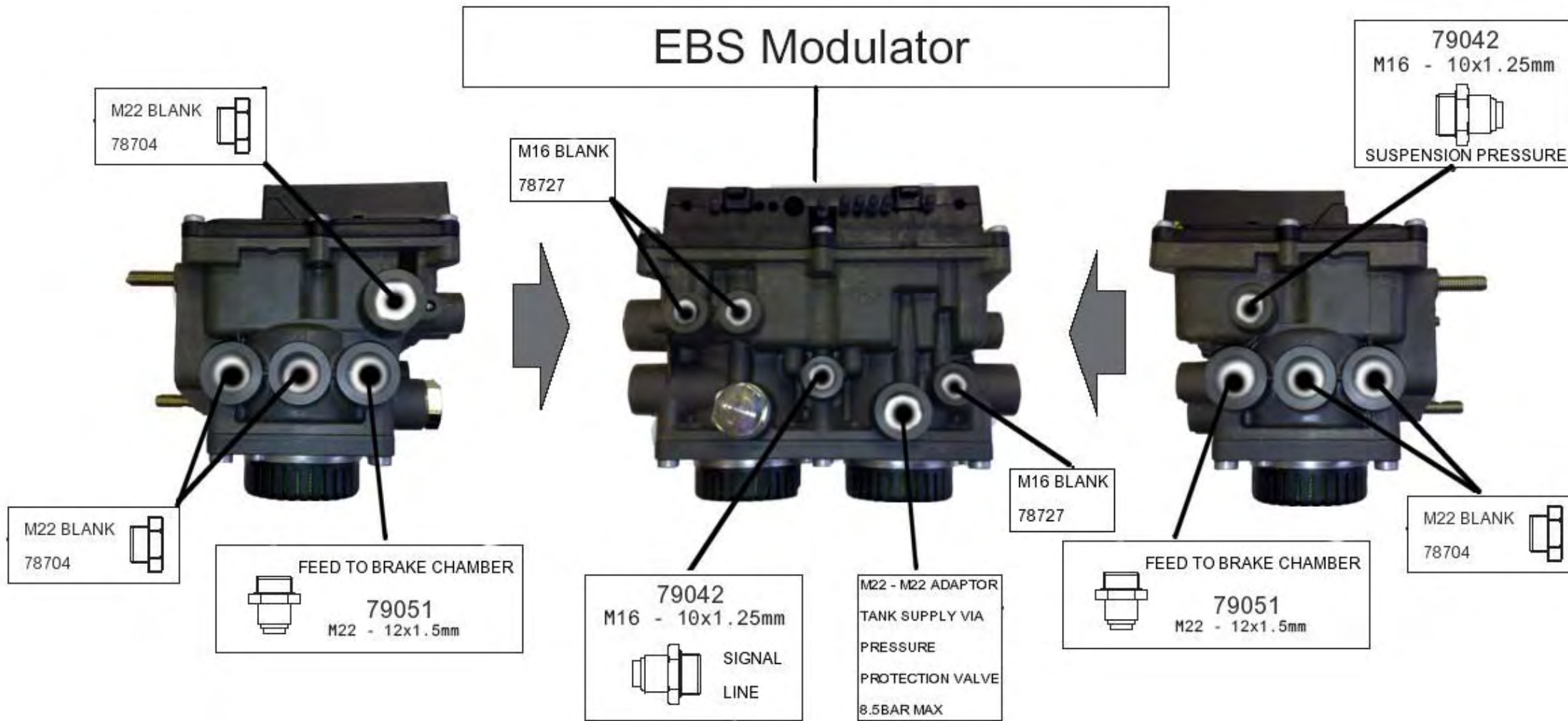

Knorr-Bremse EBS unit wiring allocations

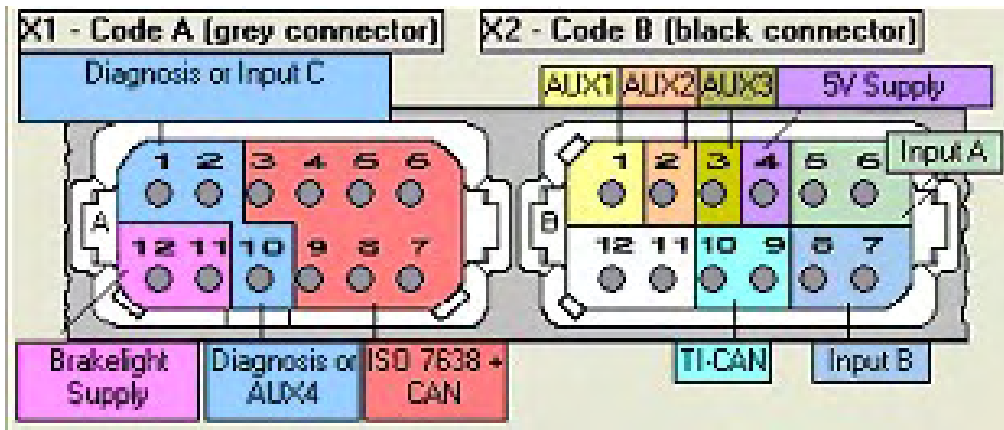

Granning Lynx UK additional axle fuse box

Fuse positions

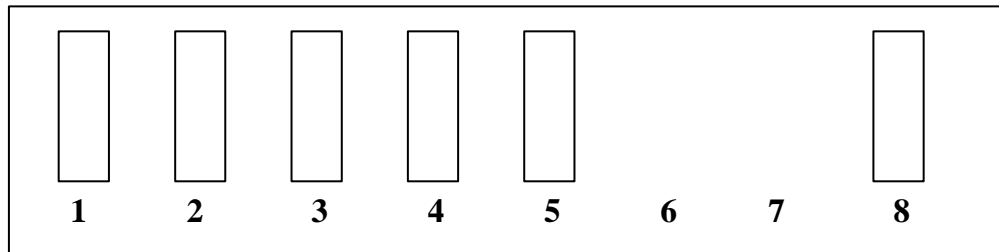

<u>Fuse Number</u>	<u>Fuse Colour</u>	<u>Fuse Rating</u>	<u>System Related</u>
1	Neutral	25Amp	EBS solenoid valve electrics Positive
2	Blue	15Amp	EBS electronics Positive
3	Blue	15Amp	EBS electronics Negative (Ground)
4	Neutral	25Amp	EBS solenoid valve electrics Negative
5	Blue	15Amp	EBS warning lamp
6	NONE	-	
7	NONE	-	
8	Tan	5Amp	Auto lower system

Repairs and Diagnostics

NOTE: Trained Wabco or Knorr-Bremse agents can be used to diagnose system faults indicated by the red light. BUT the system parameters should only be changed by or under direct instruction / authorisation of Granning Lynx UK Engineering Failure to do so will result in voiding Granning Lynx UK liability for this product.

- At NO time should the RSS function within the Trailer EBS units (TEBS) be switched on.
- Faults that occur can generally be diagnosed by a trained EBS service centre by reference to the Wabco or Knorr reference guide, by using the trouble shooting section of this manual or by contacting Granning Lynx UK engineering department.
- If the TEBS unit is to be removed due to a hardware fault, the ECU data file should be copied exactly to the new unit and Granning Lynx UK informed of this action. If the system data is unrecoverable Granning Lynx UK Engineering should be contacted to supply the original data file for uploading.
- Also for a unit change, note the installation position of the unit, as this is critical to the system program. Also please note pipe sizes and fittings that were fitted at installation, as these can be critical to system function especially the additional axle tank supply line to the TEBS unit via the pressure protection valve. Correct fittings are diagrammed previously in this manual.
- If fittings are to be changed or replaced then exact replacements or fittings of similar quality should be used as not to impair the systems integrity.
- If the pressure protection valve fails, a direct replacement should be installed or an alternative valve could be utilised adhering to the following conditions:
 - Port sizes should not be reduced as this will affect the air systems volume availability and will impair system function
 - Max pressure output of the valve should be fixed at 8.5bar
- If the charging valves are replaced then the replacements should be set to the correct opening pressure as detailed at the front of this manual and these pressures are vehicle specific, and the following conditions also adhered to:
 - The valve must be a Non-Feedback type valve
 - The valve should be fitted directly to the front or drive service tanks.
 - All fittings should be of comparable quality to originals.
 - Failure to replace the valves correctly will void Granning Lynx UK liability for this system.
- The data and Granning Lynx UK additional axle system are unique to the conversion at the time of installation. The vehicle configuration, type and dimensions should not be altered in any way without written confirmation from Granning Lynx UK.

TEBS Unit Pipe Sizes Chart

<u>Knorr Port No.</u>	<u>Wabco Port No.</u>	<u>Port size</u>	<u>Min. Pipe Size Diameter</u>	<u>Connects To</u>
1.1	1	M22	16mm	Tank supply via pressure protection valve
21+22	2	M22	12mm	Direct to service chambers
4	4	M16	10mm	Signal from TCV output yellow line
42	5	M16	10mm	Additional axle suspension bellows

- **Blanks and connector covers for TEBS electrical connections should not be removed, unless necessary to connect equipment + they should always be replaced afterwards. This applies for both the Wabco and Knorr EBS units to ensure the ingress of water is prevented as this could result in shorting across pins which will result in:**
 - **Unit not functioning correctly**
 - **Increased system degradation**
 - **Adversely affecting service life and any warranty claims.**

Troubleshooting Guide

<u>Problem</u>	<u>Fault</u>	<u>Solution</u>
No warning light for 3 seconds at ignition on	<ul style="list-style-type: none"> -Warning light bulb -Warning lamp Disconnected -System power has been disconnected - Fuse has blown (No.2) 	<ul style="list-style-type: none"> -Check axle is not lifted, no light when lifted as system is off -Check TEBS unit power connection (power supply and warning lamp connection) -Check fuses
Warning lamp illuminates when axle lowered	-No fault	-This is normal for the system, like ignition on, as system is switched off on axle lift and on again when lowered
Warning lamp stays on more 3 seconds at ignition on	<ul style="list-style-type: none"> -Possible intermittent fault -Diagnosis or service may have been performed, sensors changed or disconnected 	<ul style="list-style-type: none"> -Drive Truck at speed of greater than 10kmph with axle down, light should extinguish when new sensor etc, is seen to be working - If Not see other faults
While vehicle in motion, warning light illuminates when foot brake is applied, goes out again when released	<ul style="list-style-type: none"> -System has lost main power supply - Brake system operating on brake light feed only, ABS function available, but no EBS load sensing 	<ul style="list-style-type: none"> -Check system fuses -Check TEBS unit power connections -Check system relays
Warning lamp illuminated constantly	Sensor or hardware fault	<ul style="list-style-type: none"> -Take to Wabco/Knorr approved EBS service agent for diagnosis to check system Error log -Refer to Wabco/Knorr documentation regarding error(s) highlighted at diagnosis. -Some faults may be intermittent and can be cleared from memory. -If on diagnosis faults are not shown to be component fault or standard fault referred to by TEBS unit manufacturer, please contact Granning Lynx UK Engineering for system specific advise.